



Real-time Visibility

*RFID-enabled SAP™
Applications for
Aerospace & Defense*

Reference Guide



O A T

Transforming RFID Data into Value

Real-time Visibility: Process Areas

Innovative Aerospace and Defense firms continually look for ways to increase efficiency and eliminate waste in day-to-day operations. RFID provides the necessary visibility and measurability to drive process improvement and cost savings.

While a few Aerospace manufacturers and Defense Contractors have made an enterprise business case for RFID, many more have focused on RFID-enabling specific process areas. *Automating and error-proofing even a single business process can deliver a significant return on investment, enabling you to build value quickly as you improve processes.*

Historically, process-specific projects pay for themselves within 9-12 months, and are targeted in one of **four key areas**:

1. Supply Chain
2. Logistics & Distribution
3. Assembly Lines / Manufacturing
4. Maintenance & Repair

This guide illustrates specific areas where Aerospace OEMs, Suppliers, MRO providers and Defense Contractors can quickly and cost-effectively RFID-enable their operations, using a complex value chain as an example.

RFID in the Supply Chain

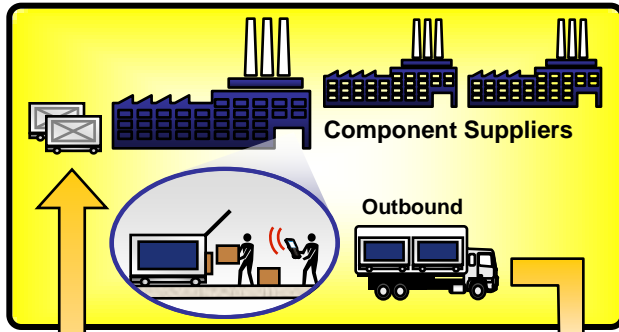

Complex manufacturing processes can involve dozens of suppliers and tens of thousands of individual components. Addressing process issues at the sourcing stage can prevent costly errors later.

- RFID tagging and tracking major components before they are shipped, in transit and at the receiving dock, prevents costly shipping errors and production delays.
- Grouping components in RFID-enabled roll cages or reusable totes prior to shipment reduces errors and logistics costs upon receipt.

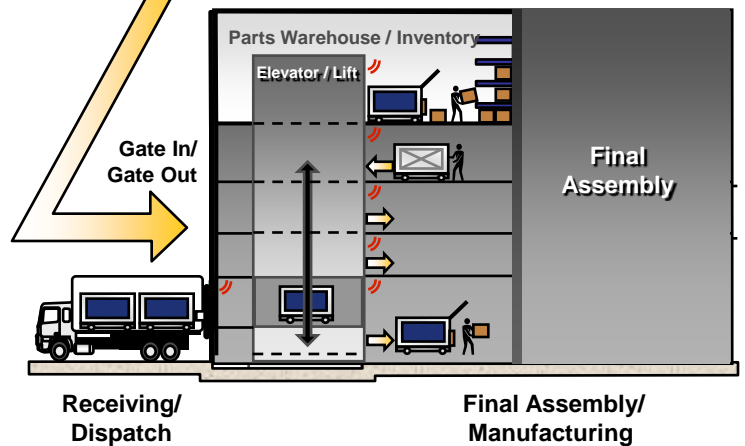
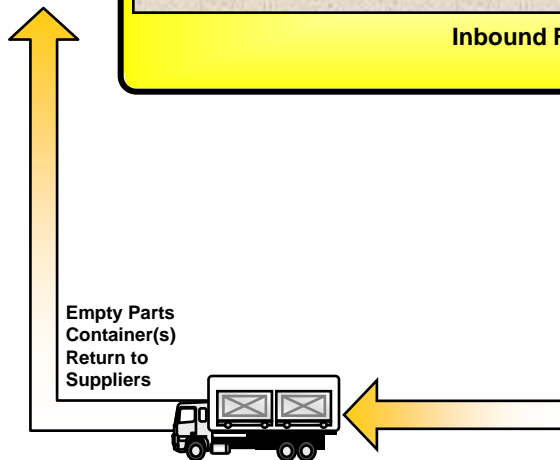
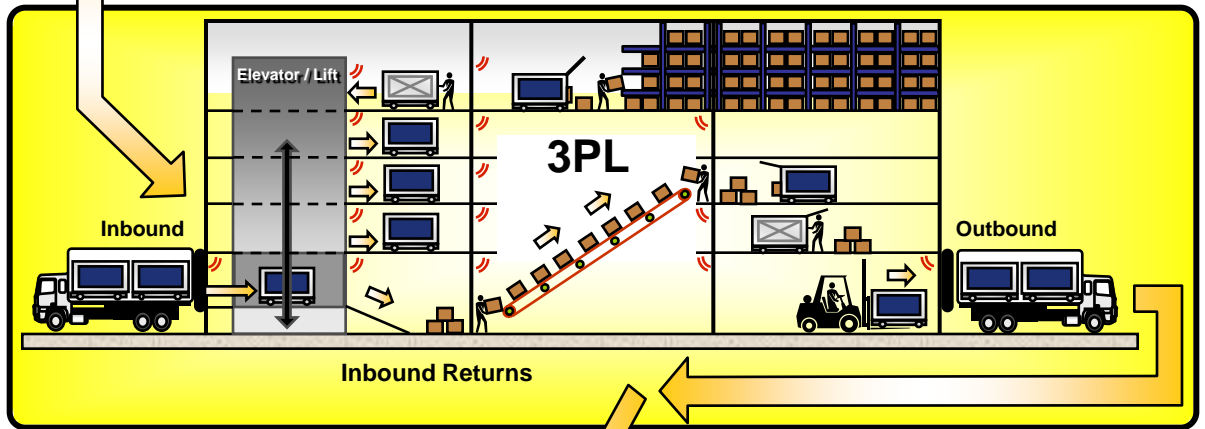

LEGEND:

- RFID Readers (Identification Checkpoints): Can be deployed using RFID portals or Mobile RFID Solution
- Full Parts Container
- Empty Parts Container

Capital goods are manufactured in large, multi-level facilities, and may involve 3PLs or cross-facility assembly processes. Components for a single product are commonly shipped to multiple areas within one location or across dozens of dispersed locations.

- Assigning a specific zone for each major component within the facility before the component is shipped, and verifying receipt with RFID reduces material management costs and reduces downtime.
- Tagging, grouping and tracking finished subassemblies by product, customer and final destination prior to shipment reduces production delays downstream.

1. Supply Chain RFID Applications

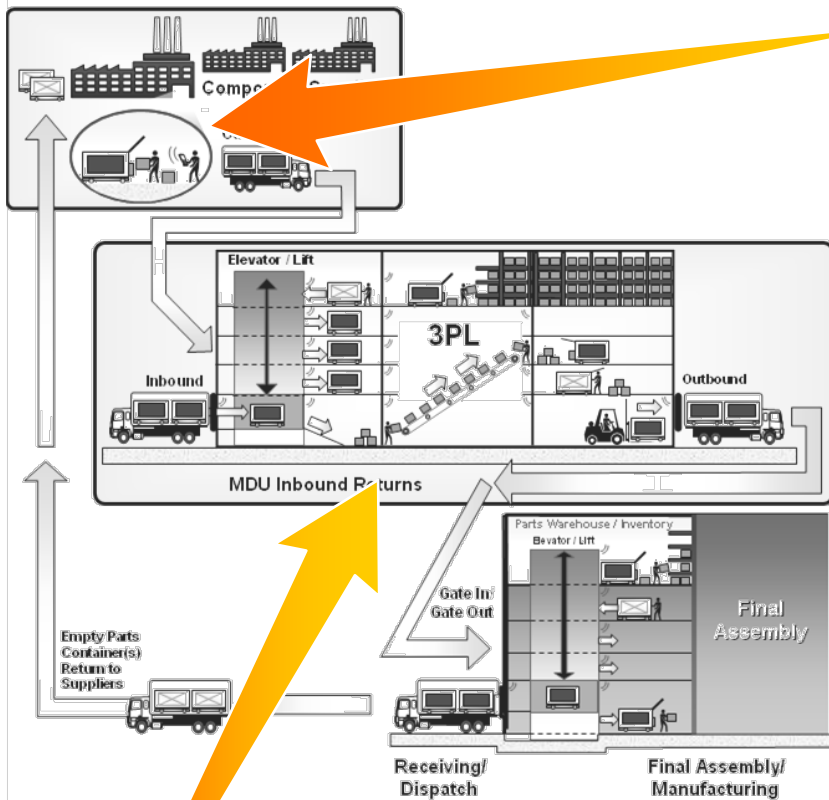

Receiving

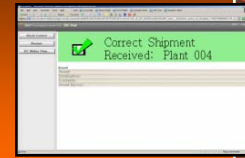

RFID Applications

- Automated Receipt and Verification of Incoming Goods
- Expediting Rush Orders
- Quarantining and Tracking Non-scheduled Shipments

ERP and WM Integration Options

- Compare Received Goods with Content Manifest or ASN
- Flag Rush Orders by Comparing Order Number and Special Instructions

RFID Value Add

- 100% Automated Tracking & Reliable Identification of Shipments as they are Received
- Focusing Staff on Exception Handling vs. Administrative Paperwork

RTI (Returnable Transport Item) Tracking

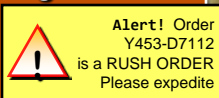

RFID Application

- Track reusable containers and contents from location to location

ERP and WM Integration Options

- Pull parts manifest for each work order to track components
- Confirm final destination for each shipment & work order number
- Alert staff with a visual or audible alarm when a work order is received in the wrong location

RFID Value Add

- Automated check-in/check-out processes
- Real time status of work orders and components

1. Supply Chain: Functional Process Flows

Receiving



Sample Process Flow

- Validating manifest details, ASN against physical shipments

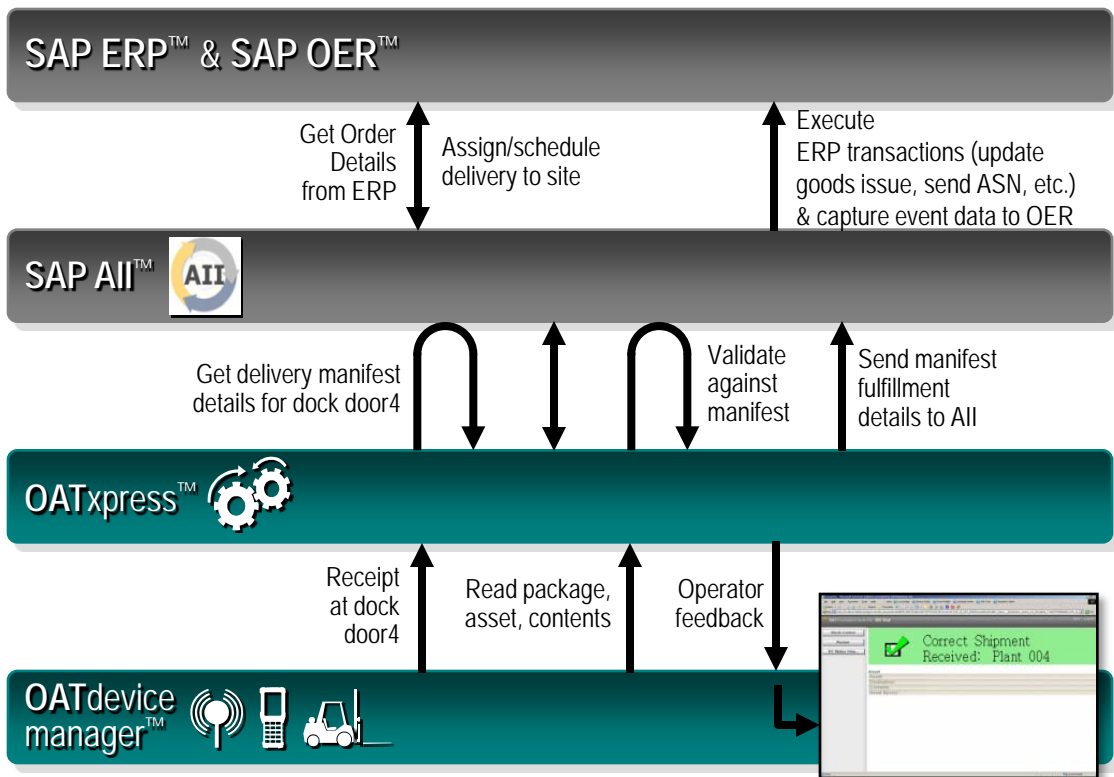

RTI (Returnable Transport Item) Tracking



Sample Process Flow

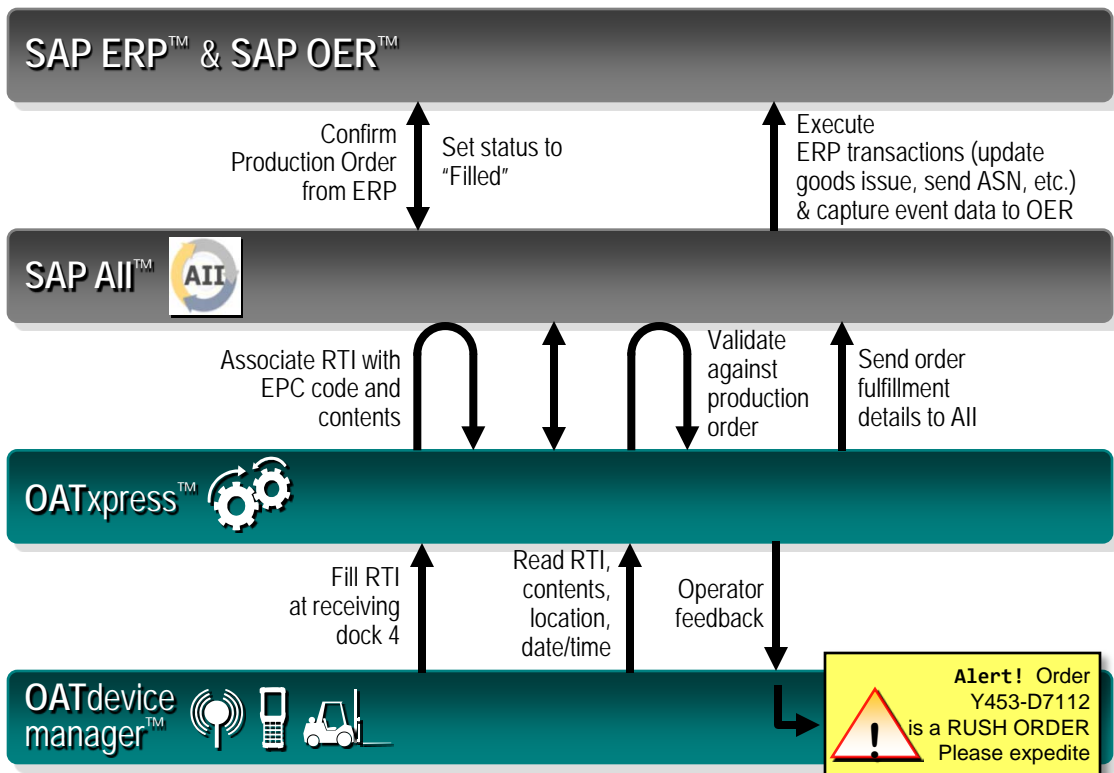

- Validating order & manifest details against physical containers and their contents

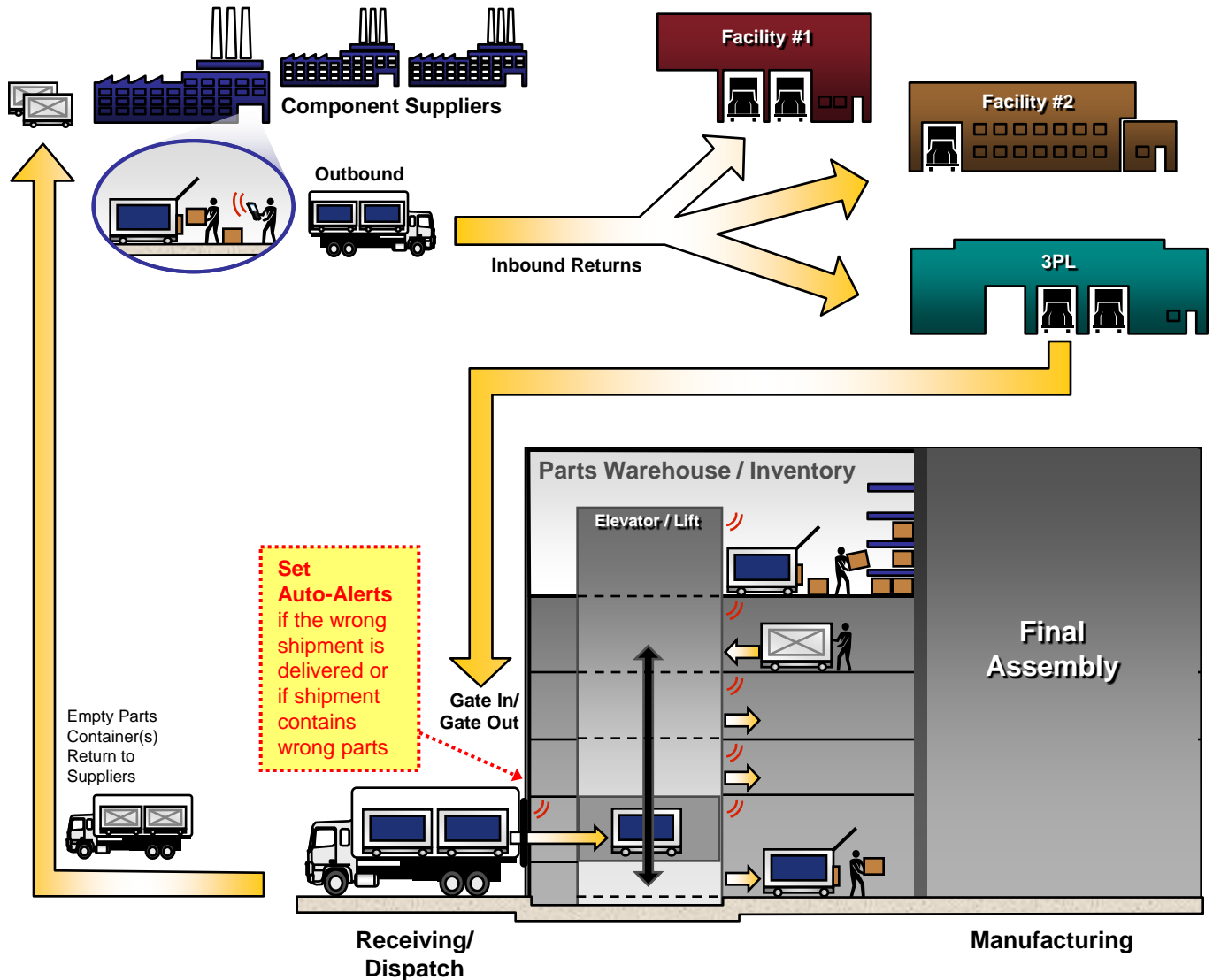

2. RFID in Logistics & Distribution



LEGEND:

-  **RFID Readers (Identification Checkpoints):**
Can be deployed using RFID portals or Mobile RFID Solution
-  **Full Parts Container**
-  **Empty Parts Container**

Many manufacturers manage materials, components and finished goods across multiple facilities. The more complex the logistics process, the more chances for shipping and receiving errors to propagate downstream. RFID-enabled processes can automatically track items once they pass through checkpoints within facilities, in transit, or at shipping and receiving points.

Tracking shipping containers, customer orders and delivery vehicles with an RFID-enabled ERP or WMS system:

- Prevents mis-shipments and make-goods, so less on-hand inventory is required at each location
- Increases product velocity, leading to higher cash flow
- Improves customer satisfaction

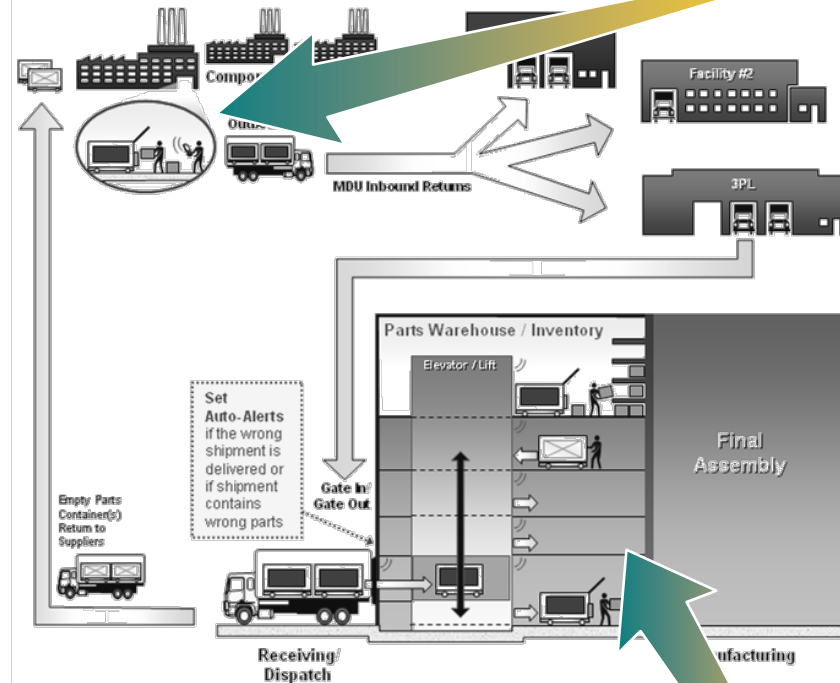

Receiving

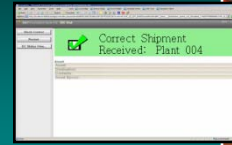

RFID Applications

- Automated Receipt and Verification of Incoming Goods
- Expediting Rush Orders
- Quarantining and Tracking Non-scheduled Shipments

ERP and WM Integration Options

- Compare Received Goods with Content Manifest or ASN
- Flag Rush Orders by Comparing Order Number and Special Instructions

RFID Value Add

- 100% Automated Tracking & Reliable Identification of Shipments as they are Received
- Focusing Staff on Exception Handling vs. Administrative Paperwork

RFID Application

- Track orders and their individual items from location to location

ERP and WM Integration Options

- Pull ASN for each order to track supplier, end customer, final destination and item numbers
- Alert staff with a visual or audible alarm when an order is received in the wrong location, or needs to be expedited

Order Tracking

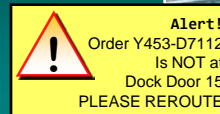

RFID Value Add

- Real time order status
- Reduce manual labor in confirmation, verification and search activities

2. Logistics & Distribution: Functional Process Flows

Receiving



Sample Process Flow

- Validating Packages against ASN

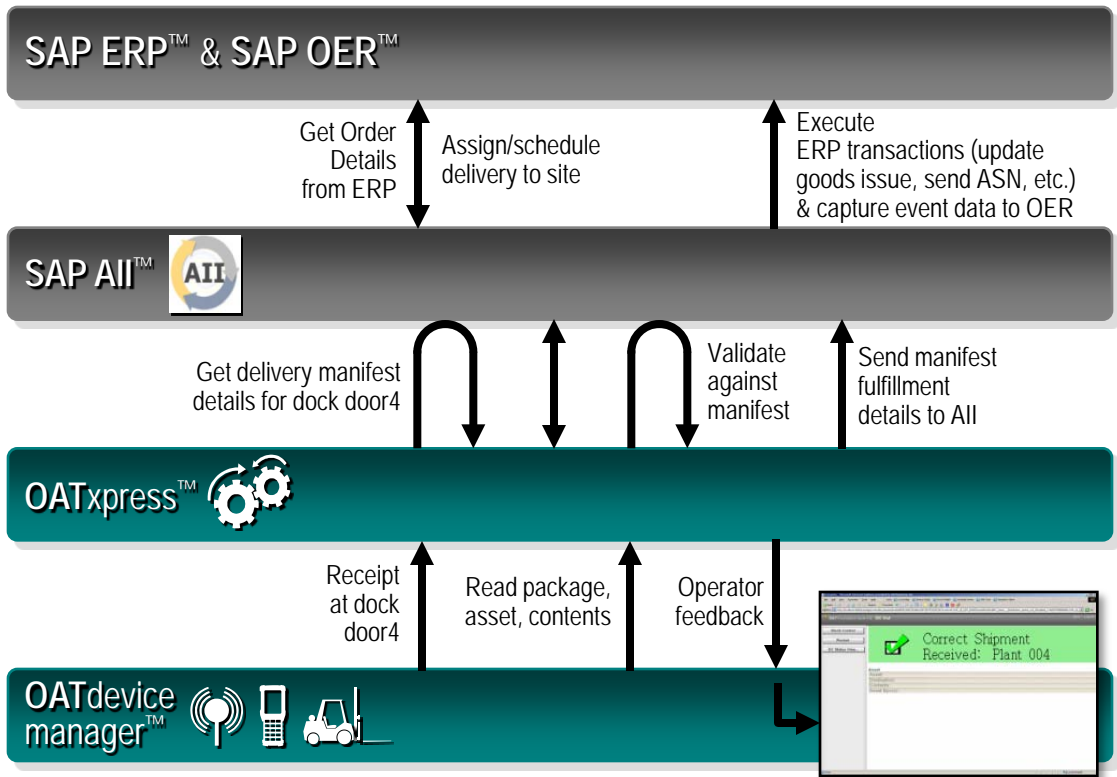

Order Tracking



Sample Process Flow

- Validate physical items against ASN & customer order to track supplier, end customer, final destination and item numbers

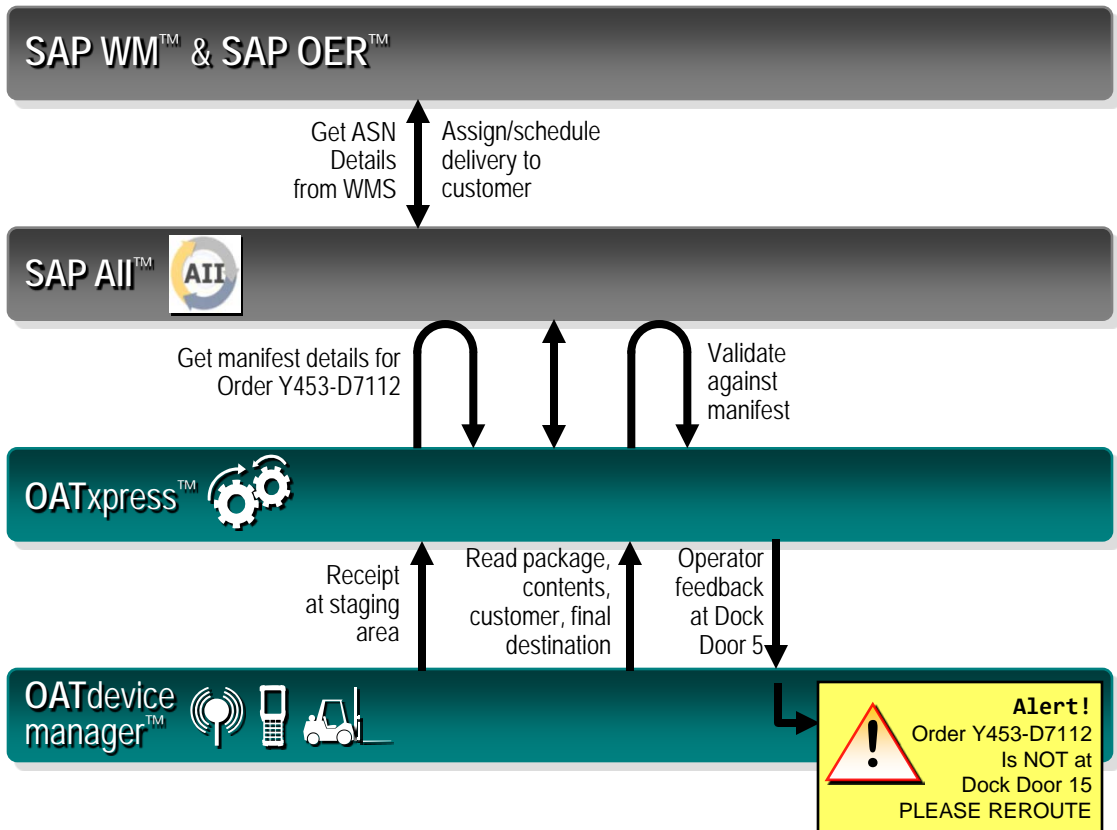

RFID in Manufacturing

It's a common practice for commercial aircraft to be physically assembled at one location and to have custom interiors installed at a second location.

At each assembly facility, a single aircraft receives parts (chairs, lighting, carpeting, catering equipment) at its own loading dock. The parts are then delivered to different floors within the assembly area. One aerospace OEM reports that the parts to assemble a single aircraft can fill over 700 rolling containers. RFID ensures that the right parts are at the right place at the right time. This reduces or eliminates the need for excess safety stock.

Final Assembly/ Manufacturing

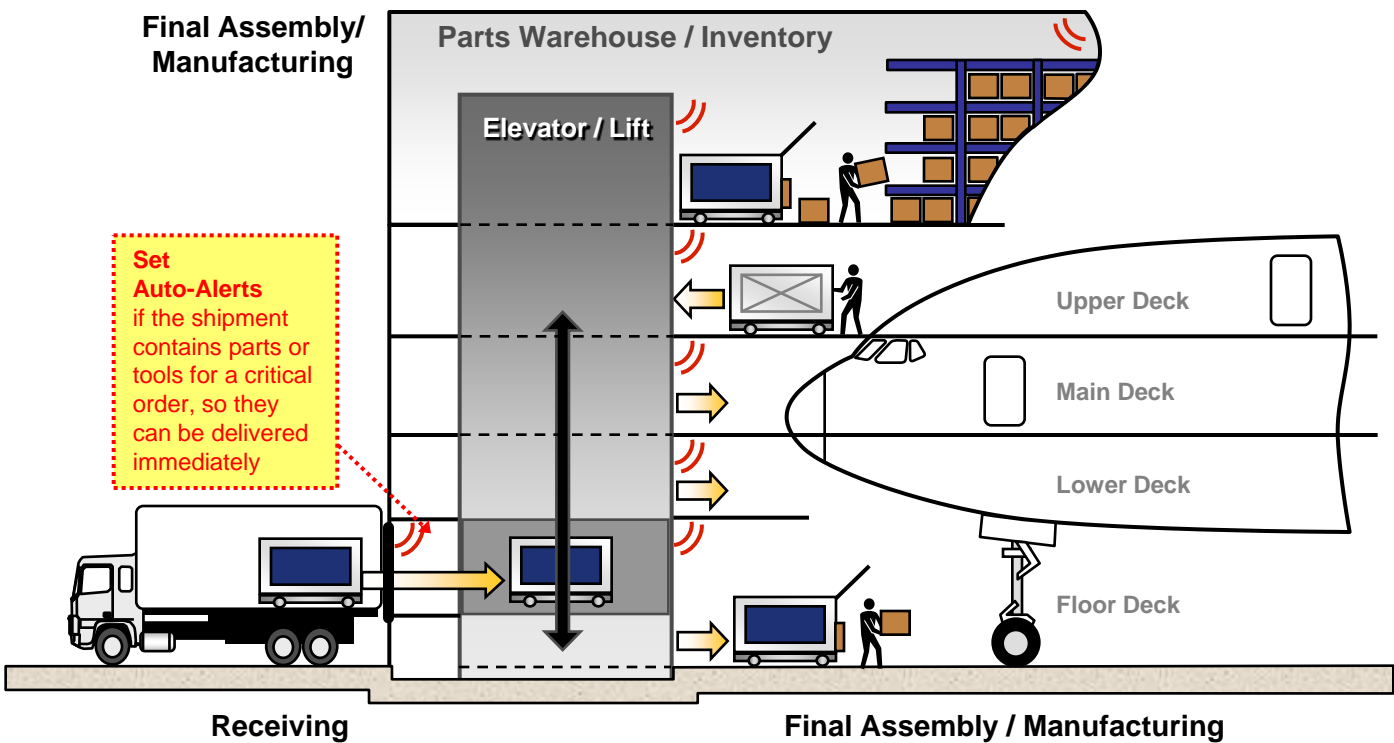

LEGEND:

 **RFID Readers (Identification Checkpoints):**
Can be deployed using RFID portals or Mobile RFID Solution

 **Full Parts Container**

 **Empty Parts Container**

- RFID-enabling ERP and MES systems provides real-time visibility into work-in process by:
 - Verifying that the correct components are delivered and installed by comparing each part against the bill of materials
 - Confirming progress of each work order as assembly progresses from one stage to the next
 - Tracking tools and equipment across the facility, eliminating manual check-in & check-out processes and production delays due to lost equipment
- Setting audible and visual alerts prevents a parts container as well as the parts themselves from being delivered to the wrong location.

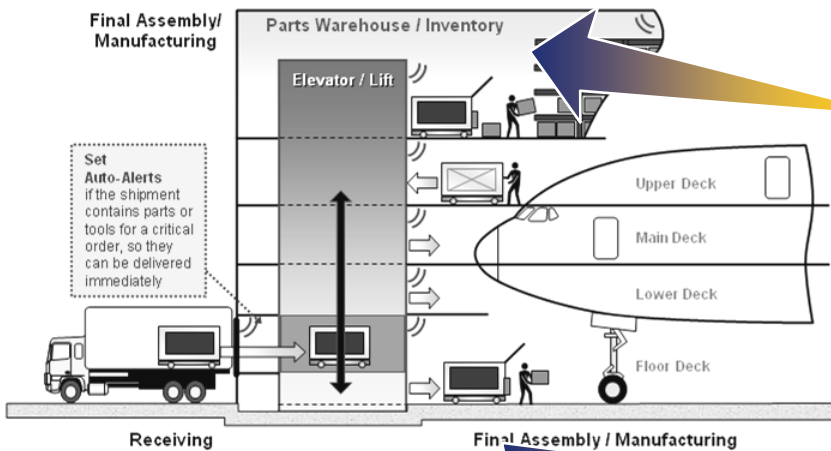

Kanban Management

Cycle Counting

Alert! Minimum Stock Level Reached. Please Reorder



RFID Applications

- Proactive Inventory Management & Automatic Replenishment

ERP and WM Integration Options

- Compare Expected Inventory with Actual Inventory
- Alert Operator or Replenish when Inventory Levels are Low

RFID Value Add

- Automated Stock Taking and Replenishment
- Reduction in Safety Stock, Labor Costs

Work in Process Tracking



RFID Applications

- Real-time Tracking of Manufacturing Work Orders, Component Parts & Subassemblies

ERP and WM Integration Options

- Update Inventory Levels and Component Parts are Assigned to New Work Orders.
- Alert Operator or Replenish Part Stores when Inventory Levels fall below a Pre-Defined Threshold

RFID Value Add

- 100% Automated Tracking & Reliable Identification of Work Orders through the Manufacturing Process
- Reduction in Safety Stock and Reusable Containers
- Help Prevent Missing Orders and Rework, Increasing Manufacturing
- Audit Trail of Components, Batch Numbers for Finished Products

Tool Tracking



RFID Applications

- Real-time Tracking of Tools and Specialized Equipment

ERP and WM Integration Options

- Verify and Update Tool Location and Maintenance Records when Tools are checked in and out

RFID Value Add

- Automated Inventory Management
- Reduction in Tool Spares
- Fewer Lost Tools, Increasing Manufacturing Uptime
- Audit Trail of Tool Usage and Maintenance Simplifies Compliance

3. Manufacturing: Functional Process Flows

Kanban/ Cycle Counting



Sample Process Flow

- Inventory Verification and Auto-Replenishment

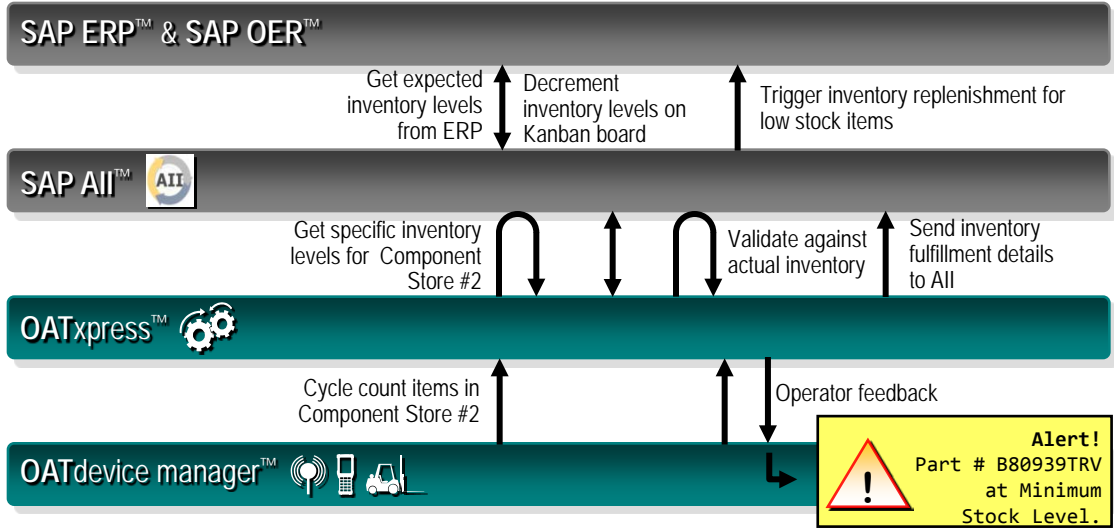

Work-in-Process Tracking



Sample Process Flow

- Verifying Components as they are Assigned to Work Orders

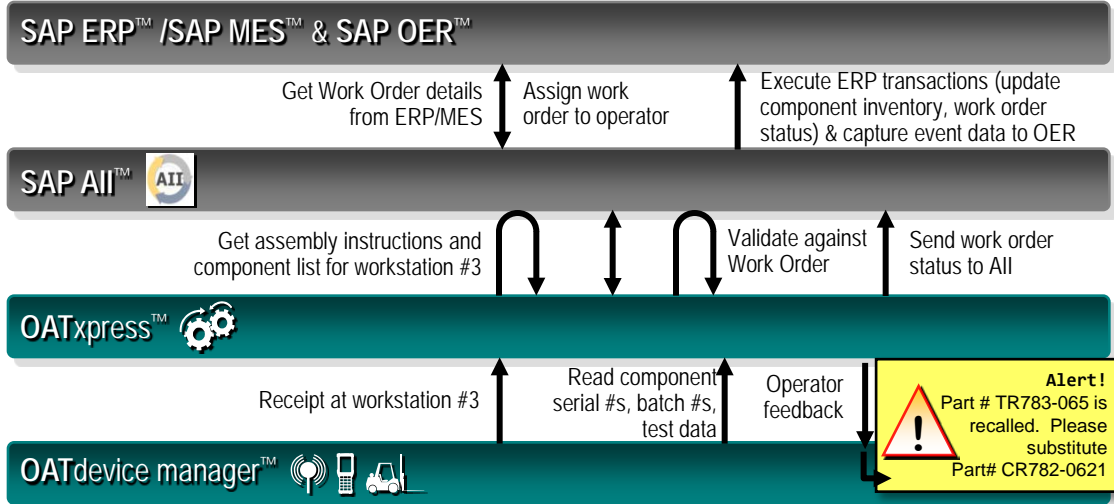

Tool Tracking



Sample Process Flow

- Verifying Tool Location and Maintenance during Check-In – Check-Out Process

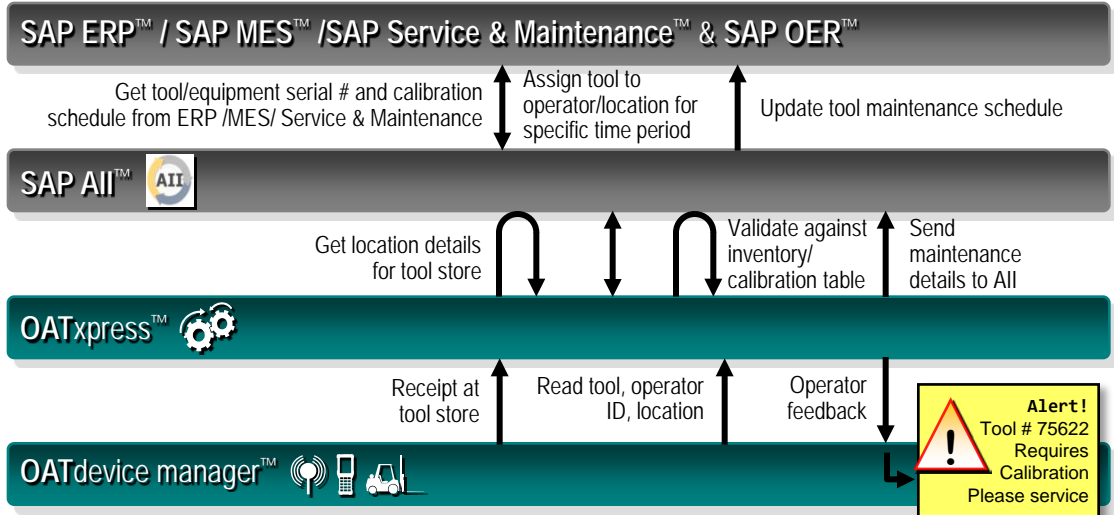

RFID in MRO Operations

A commercial aircraft is checked and maintained before and after each flight, on the ground and inside the cabin...

- RFID-enabled MRO systems track tools, equipment and maintenance schedules to:
 - Alert service personnel to previously unchecked or recalled components
 - Closely track and replenish replacement parts
 - Increase time in-service

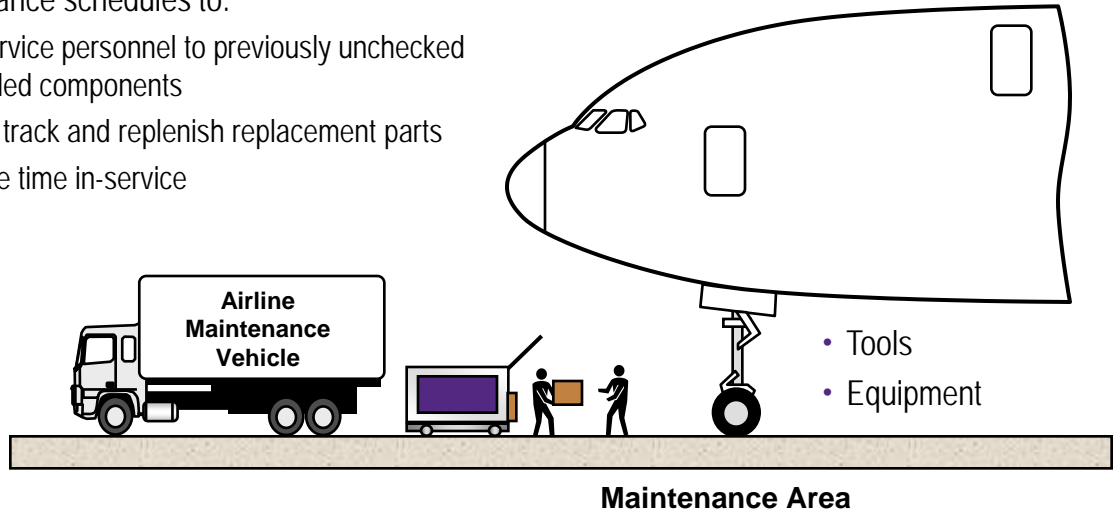

- Inside the cabin, safety equipment can be quickly scanned with hand-held RFID readers to ensure that:
 - The catering order is complete and correct
 - The passenger cabin and each seating area have the required safety equipment
 - The correct number of life jackets, masks, oxygen containers and other critical items are on-board and have not expired

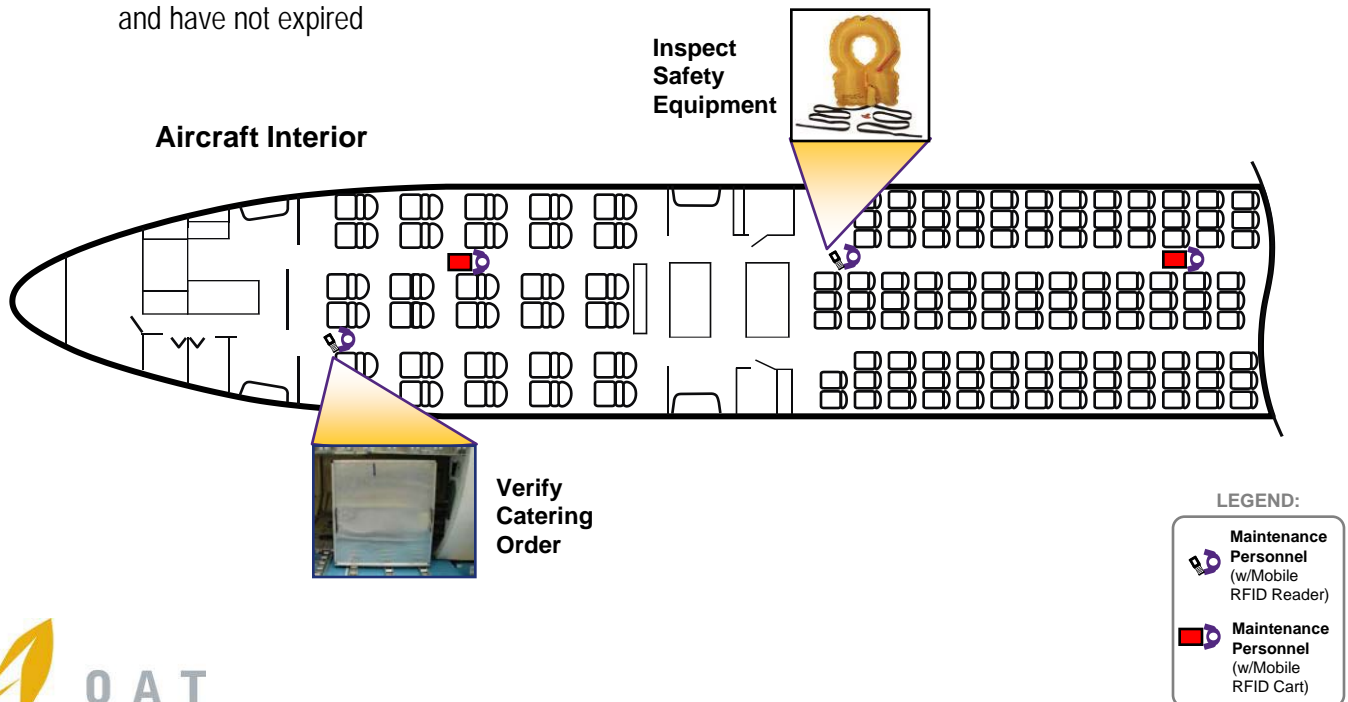

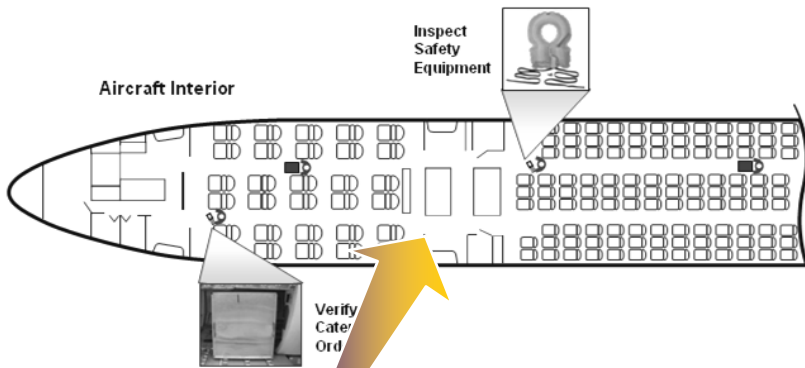
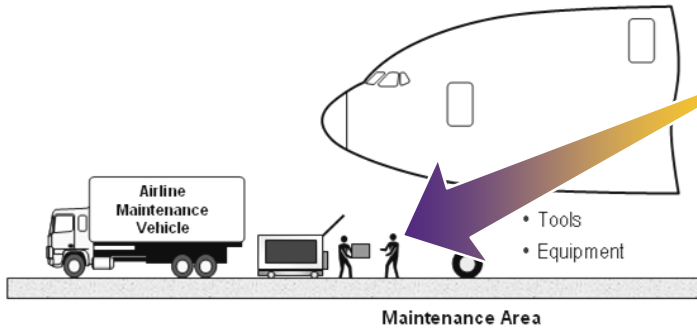

Tool and Part Management



RFID Applications

- Real-time Tracking of Tools, Specialized Equipment and Spares

ERP and WM Integration Options

- Verify and Update Tool Location and Maintenance Records when Tools are checked in and out
- Confirm spare parts match Bill of Materials

RFID Value Add

- Real-time Inventory Management
- Reduction in Tool Spares
- Fewer Lost Tools, Faster Turnaround Time
- Audit Trail of Tool Usage and Maintenance Simplifies Compliance

Audit & Inspection



RFID Applications

- Real-time Tracking of MRO Activities and Maintenance Schedules
- Automated Stock Taking and Replenishment Reconciliation

ERP and MRO Integration Options

- Verify and Update Maintenance Records when Aircraft is Serviced
- Confirm Required Components (Oxygen Canisters, Life Vests) are On Board
- Alert Staff if a specific component is missing, near or past expiration date, or requires maintenance

RFID Value Add

- Faster Turnaround Time at Maintenance and at the Gate
- Fewer Spare Components Required
- Audit Trail of Maintenance & Inspection Activities Simplifies Compliance

4. MRO: Functional Process Areas

Tool & Part Management



Sample Process Flow

- Confirm spare parts match Bill of Materials

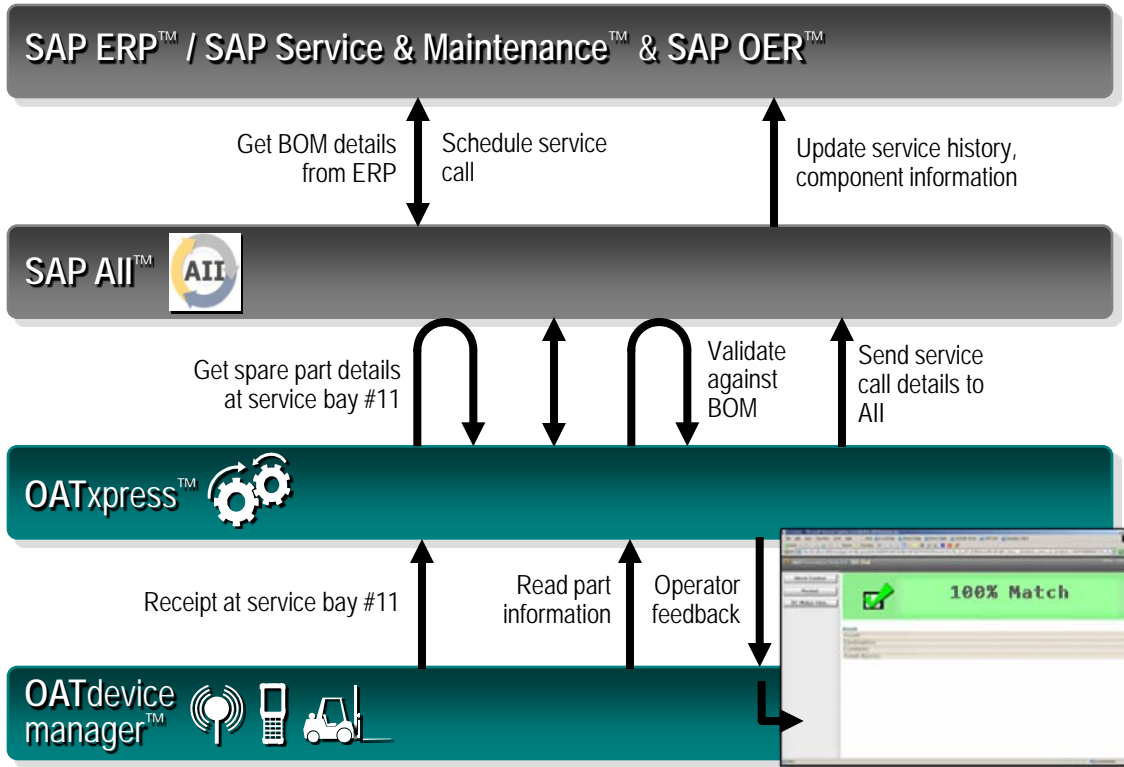

Audit & Regulation



Sample Process Flow

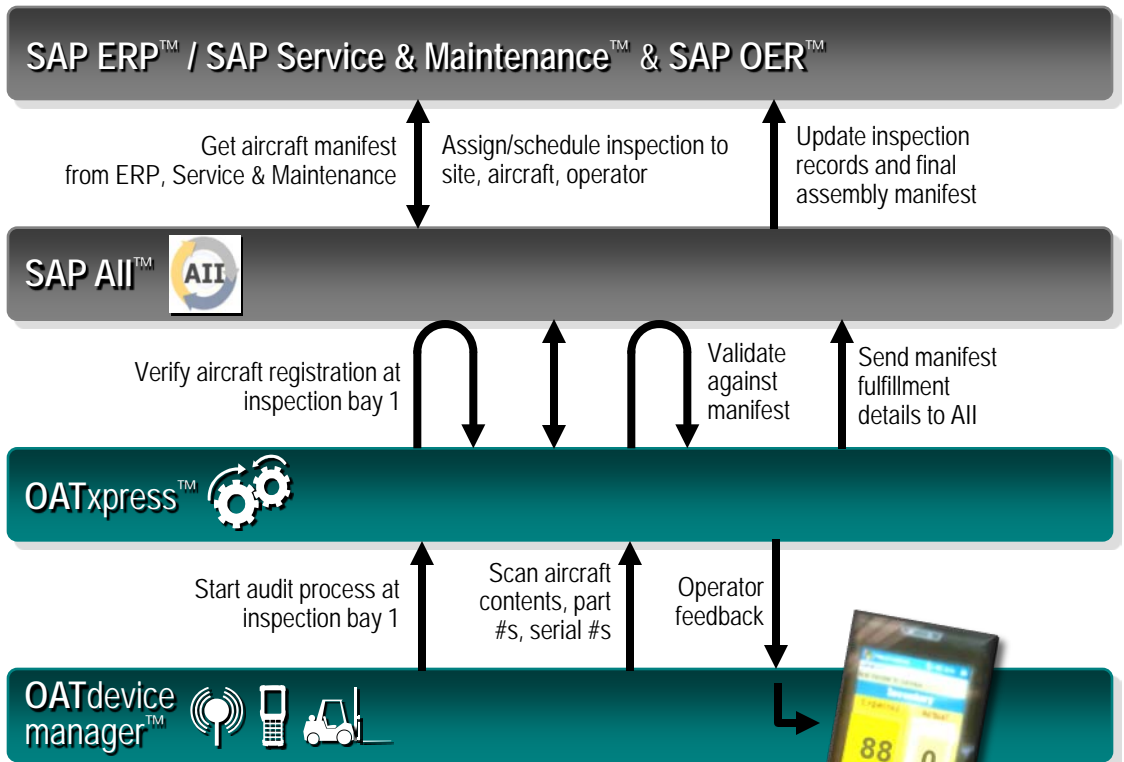

- Confirm required components are on board aircraft



-88 Life Vests on Board
- 0 Compliance Issues

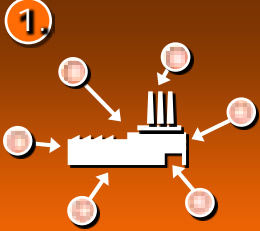
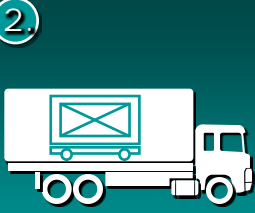
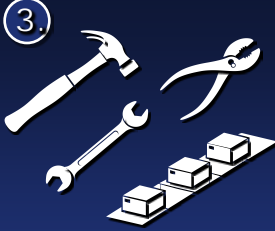

RFID-enabling Key Process Areas

	 1. Supply Chain	 2. Logistics & Distribution	 3. Manufacturing/ Assembly Lines	 4. Maintenance & Repair
Items to Track:	<ul style="list-style-type: none"> • Component Parts • Supplier • Batch Number • Due Date 	<ul style="list-style-type: none"> • Carrier • Order Number • Order Contents • Final Destination • Due Date 	<ul style="list-style-type: none"> • Work-in-Process • Tools and Equipment • Test Results • Custom Order Details 	<ul style="list-style-type: none"> • Service History • Replacement Parts • Part Expiration Date • Service Due Date
Processes to Enable:	Sourcing	Receiving Reverse Logistics	Assembly Asset Tracking	MRO
Quantifying Value:	Increased Forecast Accuracy Reduced Safety Stock	Streamlined Shipping Costs Increased Order Accuracy & Customer Satisfaction	Improved Product Quality, Fewer Returns Reduced Downtime Reduced Scrap & Rework	Increased Time in Service Fewer Audits & Regulatory Fines Reduced Maintenance and Repair Costs

While every manufacturing and services operation is unique, there are common operational challenges that can be addressed with real-time visibility. By automating and error-proofing critical processes, RFID-enabling existing applications and implementing RFID packaged solutions, Aerospace Manufacturers and Defense Contractors can reduce deployment time and accelerate the return on their technology investment.

Leveraging Your Production Systems

	<h2>RFID Integration Examples</h2>
Enterprise Resource Planning (ERP) Systems	<ul style="list-style-type: none"> • Verify physical components against bill of materials • Trigger inventory replenishment when low stock is detected
Manufacturing Execution Systems (MES)	<ul style="list-style-type: none"> • Track physical products at each stage of testing & assembly • Confirm that custom orders match manifest • Locate missing parts & equipment
Warehouse Management Systems (WMS)	<ul style="list-style-type: none"> • Verify manifest & destination for outgoing shipments • Prevent mis-shipments with visual/audible alarms • Track finished goods inventory
Maintenance & Repair (MRO) Systems	<ul style="list-style-type: none"> • Verify parts & equipment against service orders • Monitor installation & maintenance history • Locate recalled or expired service parts
Business Activity Monitoring (BAM) Dashboards	<ul style="list-style-type: none"> • Automatically update dashboards to reflect: <ul style="list-style-type: none"> – Physical inventory levels – Orders shipped – Manufacturing efficiency

ERP, MES, WMS, MRO systems & business activity dashboards are the lifeblood of many manufacturing and services organizations. RFID-enabling these production systems incorporates real-time production and delivery status into day-to-day business metrics. This enables staff to uncover and address process errors before they impact production schedules, customer orders and downtime.

About OATSystems

OATSystems has helped more than 100 companies take advantage of RFID to streamline operations, enhance customer satisfaction and increase bottom line results. OAT is the recognized RFID solution leader with software that empowers businesses to achieve a competitive advantage and ROI from RFID. As a pioneer in the development of RFID technology, OAT has been setting the standard in RFID for over half a decade and has provided RFID-enabled solutions to leading companies such as Airbus, Chevron, Best Buy, Tesco, Kimberly-Clark, Cephalon, Shell, Tyco Electronics and others.

Contact OATSystems today at www.oatsystems.com or 781-907-6100 and get ready to take control of your operations.

Corporate Office:

OATSystems
200 West Street
Waltham MA 02451
USA
781-907-6100

International Sales:

OATSystems
68 Lombard Street
London EC3V 9LJ
United Kingdom
+44 20 7868 1704

www.oatsystems.com

